

Cast-in lifting box



Installation and Application Instruction

Our products from the division BUILDING SOLUTIONS

SERVICES

- » On-site tests -> we ensure that your requirements are properly covered by our planning.
- » Test reports -> for your safety and documentation.
- » Trainings -> the knowledge of your employees from planning and production is enhanced by our experts on site, online or via webinar.
- » Planning support -> latest design software, planning documents, CAD data and much more can be downloaded any time from www.philipp-group.de.

HIGH DEMANDS ON PRODUCT SAFETY AND PRACTICALITY

- » Close cooperation with notified bodies and - if necessary - approval of our solutions.

TECHNICAL DEPARTMENT

- » Our expert-team will support you at any time during your planning phase with detailed advice.

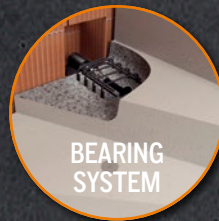
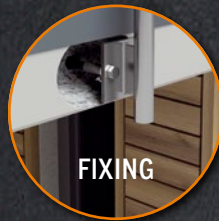
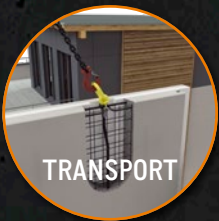

CONTENT

THE PHILIPP CAST-IN LIFTING BOX IN WALLS	Page	4
THE CAST-IN LIFTING BOX	Page	5
GENERAL PRODUCT INFORMATION	Page	6
Materials	Page	6
Element thicknesses, centre and edge distances	Page	6
Concrete compressive strength	Page	6
Reinforcement	Page	6
Load directions	Page	6
Bearing capacities	Page	6
Storage of the Cast-in lifting box	Page	6
CAST-IN LIFTING BOX IN WALL-LIKE ELEMENTS	Page	7
CAST-IN LIFTING BOX IN COLUMN-LIKE ELEMENTS	Page	8
CAST-IN LIFTING BOX IN BEAM-LIKE ELEMENTS	Page	10
GENERAL PRODUCT INFORMATION	Page	12
Marking	Page	12
INSTALLATION	Page	13
PREPARATION FOR APPLICATION / SAFETY INSTRUCTIONS	Page	14
Preparation for application	Page	14
Safety instructions	Page	14

PHILIPP Cast-in lifting box

THE PHILIPP CAST-IN LIFTING BOX IN WALLS

YOUR BENEFITS AT A GLANCE:

- » New transport anchor with load capacity up to 4 t
- » Transport anchor system with outstanding price performance ratio
- » Simple, penetration-free installation directly on the formwork (no need for a recess or similar)
- » No need for a special lifting device in factory or on-site
- » Time-efficient handling: fold out the loop and ready for transportation
- » The open and flexible end anchoring enables transport solutions in very slim concrete areas shaped column-like or beam-like
- » High quality and safety standards



THE CAST-IN LIFTING BOX

The Cast-in lifting box is part of the PHILIPP Transport anchor system which complies with the VDI/BV-BS Guideline "Lifting inserts and lifting systems for precast concrete elements" (VDI/BV-BS 6205). Use of the Cast-in lifting box requires compliance with this Installation and Application as well as the General Installation Instruction.

A Cast-in lifting box is designed for the transport of precast concrete units only. Multiple use within the transport chain (from production to installation of the unit) means no repeated usage. A repeated use (e.g. ballasts for cranes) is not allowed.

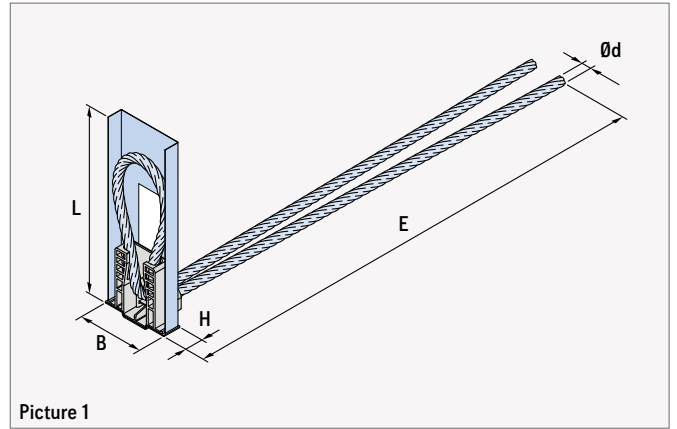

Picture 1

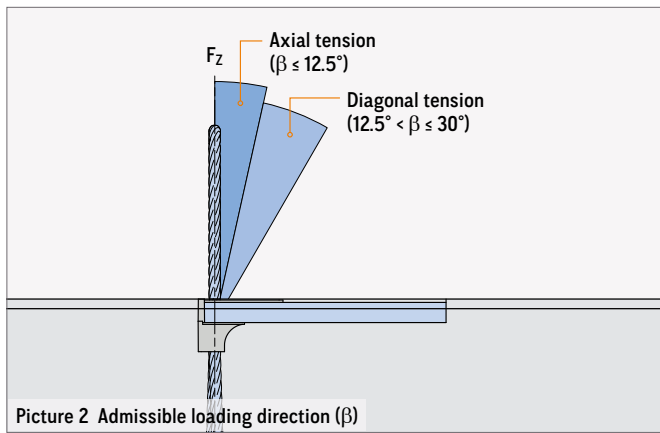

Picture 2 Admissible loading direction (β)

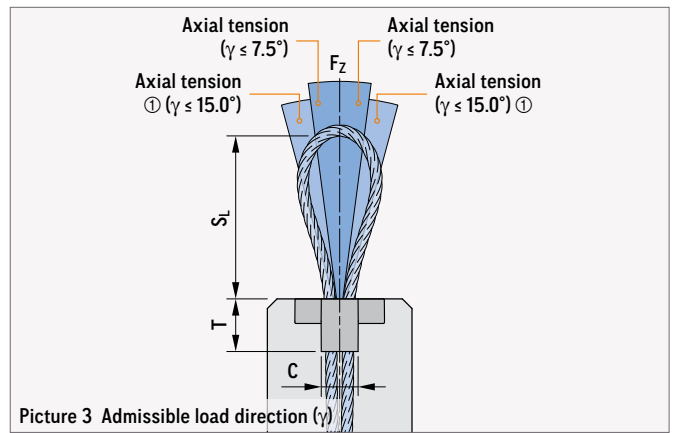

Picture 3 Admissible load direction (γ)

① Only usable if a tilting table is used!

TABLE 1: DIMENSIONS

Ref. no.	Type	Dimensions							
		H (mm)	B (mm)	L (mm)	S_L ② (mm)	E ② (mm)	T (mm)	C (mm)	$\varnothing d$ ③ (mm)
44DAH040	AS 4.0	25	90	255	175	650	56	40	12

② Dimensions S_L and E are standard values and can vary depending on the situation.

③ Rope diameter $\varnothing d$ is a standard value and can vary depending on the wire rope construction.

GENERAL PRODUCT INFORMATION

MATERIALS

The Cast-in lifting box consists of a metal recess box and a plastic bracket with a galvanized, angled wire rope loop, which will be folded out for lifting. This galvanisation is aimed at protecting the anchor temporarily during storage until the final installation in concrete elements.

ELEMENT THICKNESSES, ANCHOR SPACING AND EDGE DISTANCES

The installation and positioning of Lifting box in precast concrete elements require minimum element thickness, anchor spacing and edge distances to ensure a safe load transfer. These values can be found in the tables for the individual cases of application.

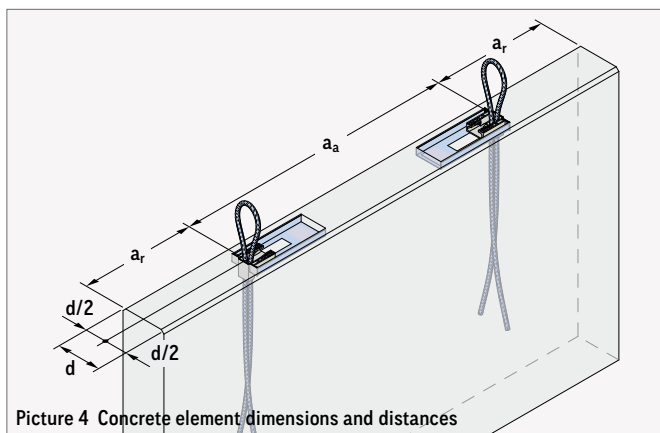

CONCRETE COMPRESSIVE STRENGTH

At the time of the first lift the concrete must have a minimum strength f_{cc} acc. to table 2, 3 or 5. Given concrete strengths f_{cc} are cube compression strengths at the time of the first lifting.

REINFORCEMENT

A Cast-in lifting box requires a minimum reinforcement according to table 3, 4 or 6. This minimum reinforcement guarantees a safe load transfer in concrete elements. The user is personally responsible for further transfer of load into the concrete unit.

LOAD DIRECTIONS

During transport of the concrete elements only a diagonal tension on the anchors up to β_{max} 30° as well as a lateral tension up to γ_{max} 7.5° are admissible! A lateral tension on the concrete elements up to γ_{max} 15° is admissible in combination with a tilting table by the first lifting. A diagonal tension on the anchors of $\beta > 30^\circ$ as well as a lateral tension $\gamma > 15^\circ$ are not admissible!

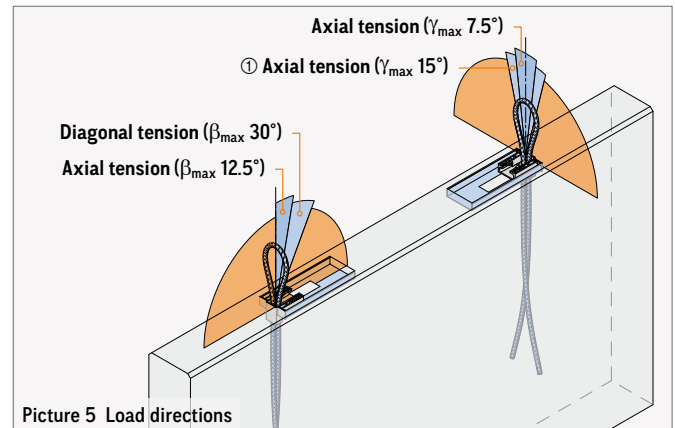

① Only in combination with a tilting table!

BEARING CAPACITIES

Details of the load bearing capacities and boundary conditions dependent on the concrete compressive strengths are given in tables 2, 4 and 5.

STORAGE OF THE CAST-IN LIFTING BOX

Cast-in lifting boxes shall be stored in a clean, dry and aerated area, without contact to acids, bases or corrosive elements.



EXISTING REINFORCEMENT

Existing static or constructive reinforcement can be taken into account for the minimum reinforcement of the respective load case.

LIFTING BOX IN WALL-LIKE ELEMENTS

In case of an installation in wall-like elements, the minimal dimensions of the concrete element as well as edge and centre distances given in have to be considered. For the information about required reinforcement please also refer to table 2.

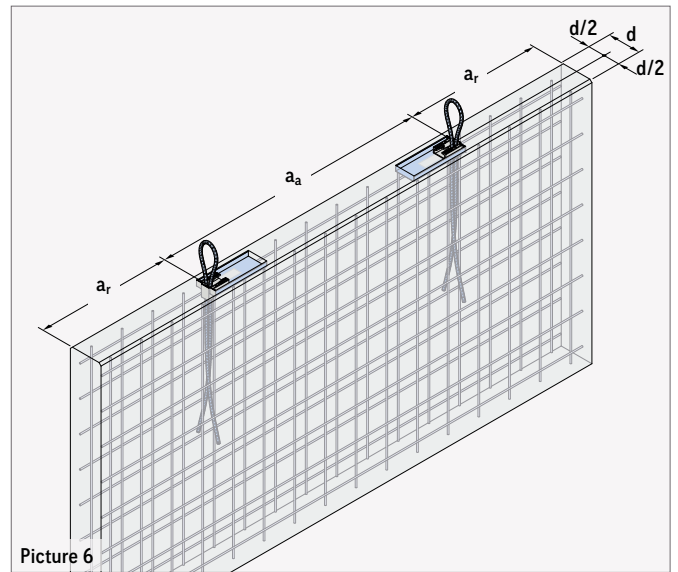
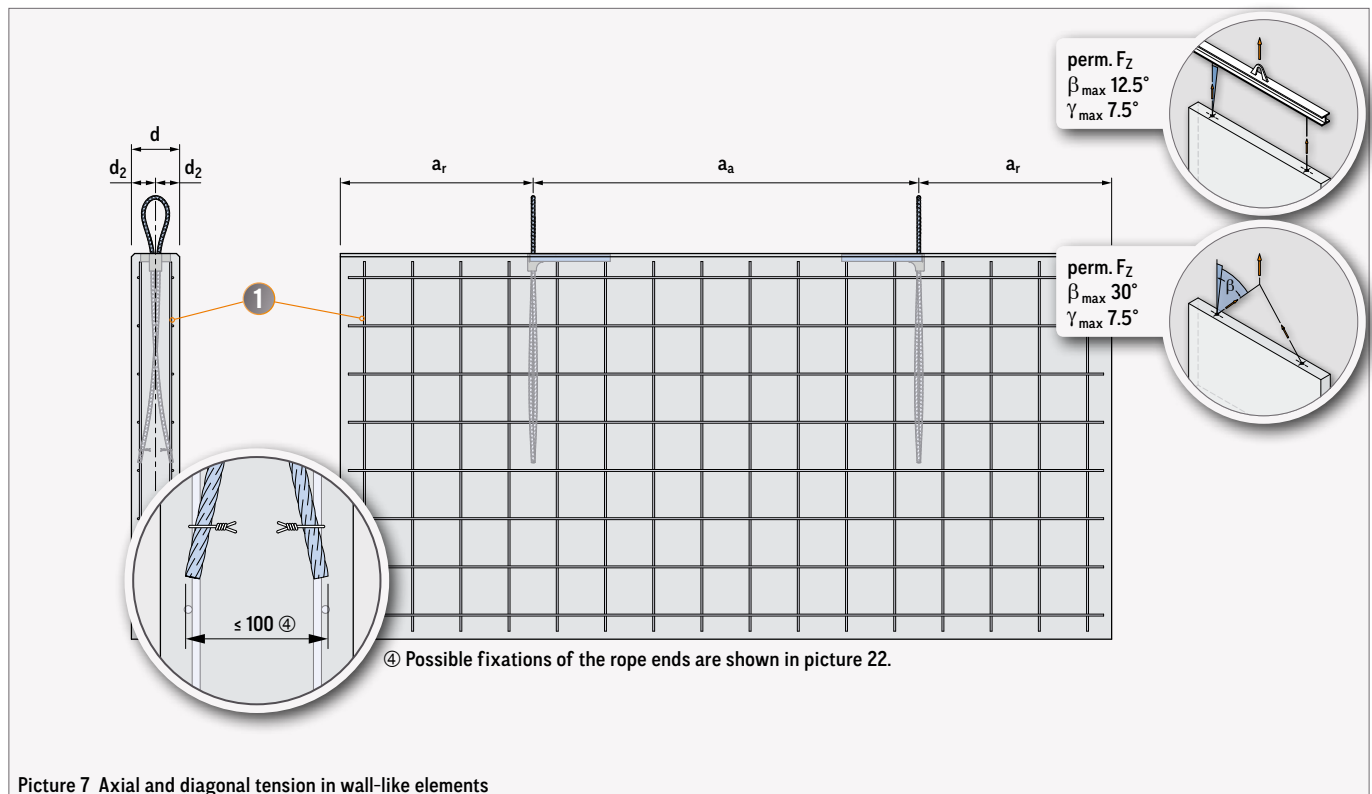

TABLE 2: AXIAL AND DIAGONAL TENSION IN WALL-LIKE ELEMENTS

Load class	Min. element thicknesses min. centre and edge distances			$\beta_{\max} 30^\circ / \gamma_{\max} 7.5^\circ$ ①	
	d (mm)	a _a (mm)	a _r (mm)	perm. F _Z f _{cc} ≥ 15 N/mm ² (kN)	Mesh reinforcement (square) (mm ² /m)
4.0	150	1200	600	40.0	2 × #188

① In combination with a tilting table $\gamma_{\max} 15^\circ$ is possible!



PHILIPP Cast-in lifting box

CAST-IN LIFTING BOX IN COLUMN-LIKE ELEMENTS

In case of an installation in column-like elements, the minimal dimensions of the concrete element as well as edge and centre distances given in have to be considered. For the information about required reinforcement please also refer to table 3. Data of required reinforcement are given in table 4 as well.

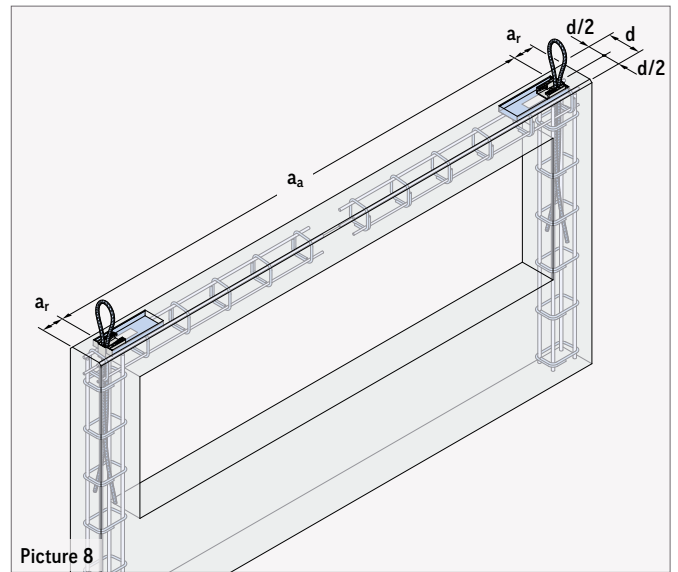
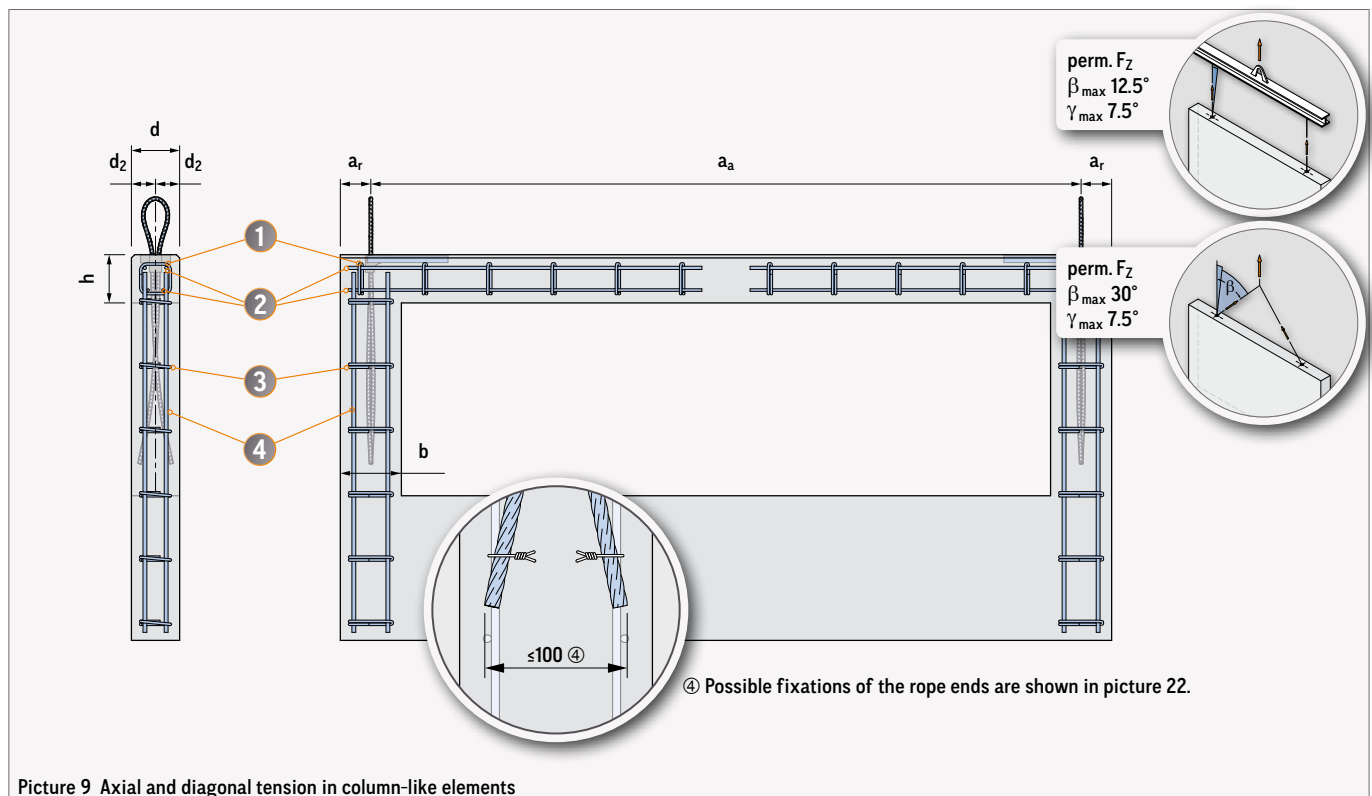

TABLE 3: AXIAL AND DIAGONAL TENSION IN COLUMN-LIKE ELEMENTS

Load class	Min. element thicknesses min. centre and edge distances					$\beta_{\max} 30^\circ / \gamma_{\max} 7.5^\circ$ ①	
	d (mm)	a _a (mm)	a _r (mm)	h (mm)	b (mm)	perm. F _Z f _{cc} ≥ 15 N/mm ² (kN)	perm. F _Z f _{cc} ≥ 17.5 N/mm ² (kN)
4,0	150	1530	95	150	190	39.8	40.0

① In combination with a tilting table $\gamma_{\max} 15^\circ$ in possible!



④ Possible fixations of the rope ends are shown in picture 22.

CAST-IN LIFTING BOX IN COLUMN-LIKE ELEMENTS

TABLE 4: REINFORCEMENT

Load class	Beam				Column			
	① ⑤ Stirrup (B500A/B)		② Longitudinal reinforcement (B500A/B)		③ ⑤ Stirrup (B500A/B)		④ Longitudinal reinforcement (B500A/B)	
	$\varnothing d_{B1}$ (mm)	$\varnothing d_{br1}$ (mm)	$\varnothing d_{S2}$ (Quantity. × mm)	L_{S2} (mm)	$\varnothing d_{B3}$ (mm)	$\varnothing d_{br3}$ (mm)	$\varnothing d_{S4}$ (Quantity. × mm)	L_{S4} (mm)
4.0	Ø8 / 200	Ø32	4 × Ø10	1100	Ø8 / 200	Ø32	4 × Ø12	1250

⑤ The stirrups ① + ③ can be replaced by a comparable mesh reinforcement. This requirement is fulfilled e.g. by a mesh reinforcement type Q257 A (equal 2.57 cm²/m). Existing reinforcement may be taken into account.

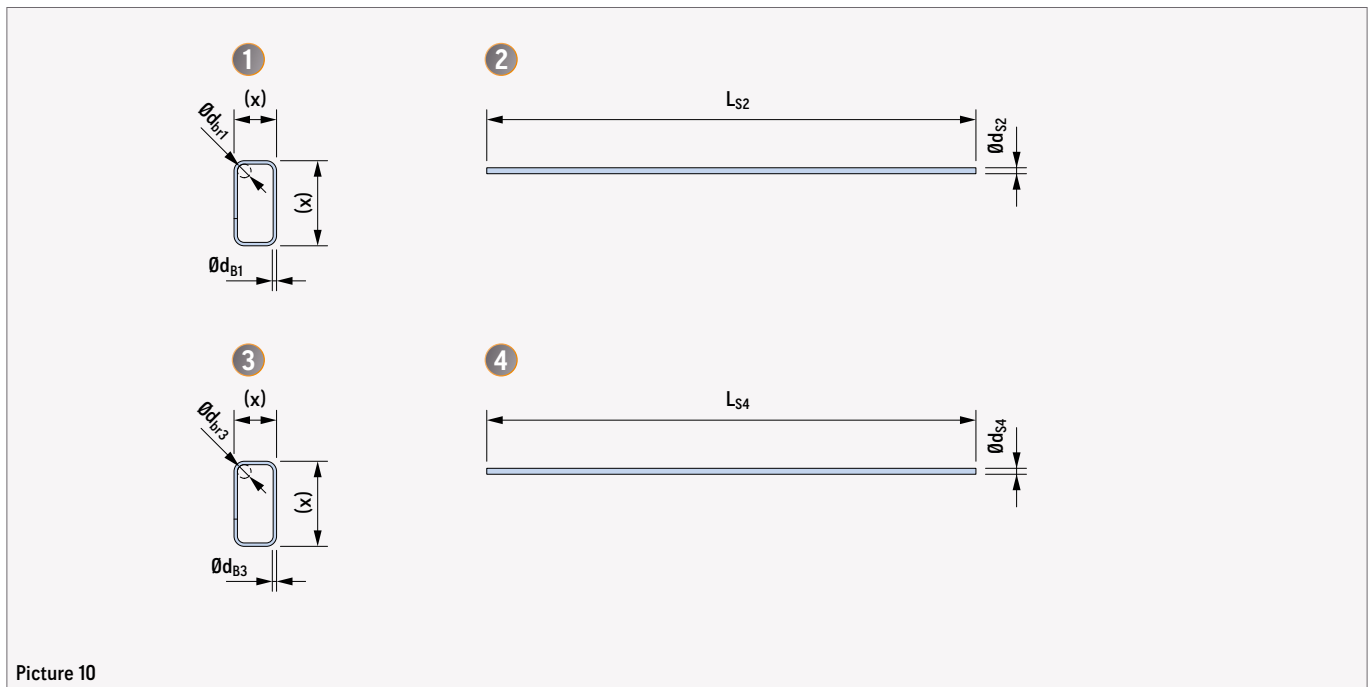

Picture 10

The measures marked with (x) depend on the respective element dimensions.

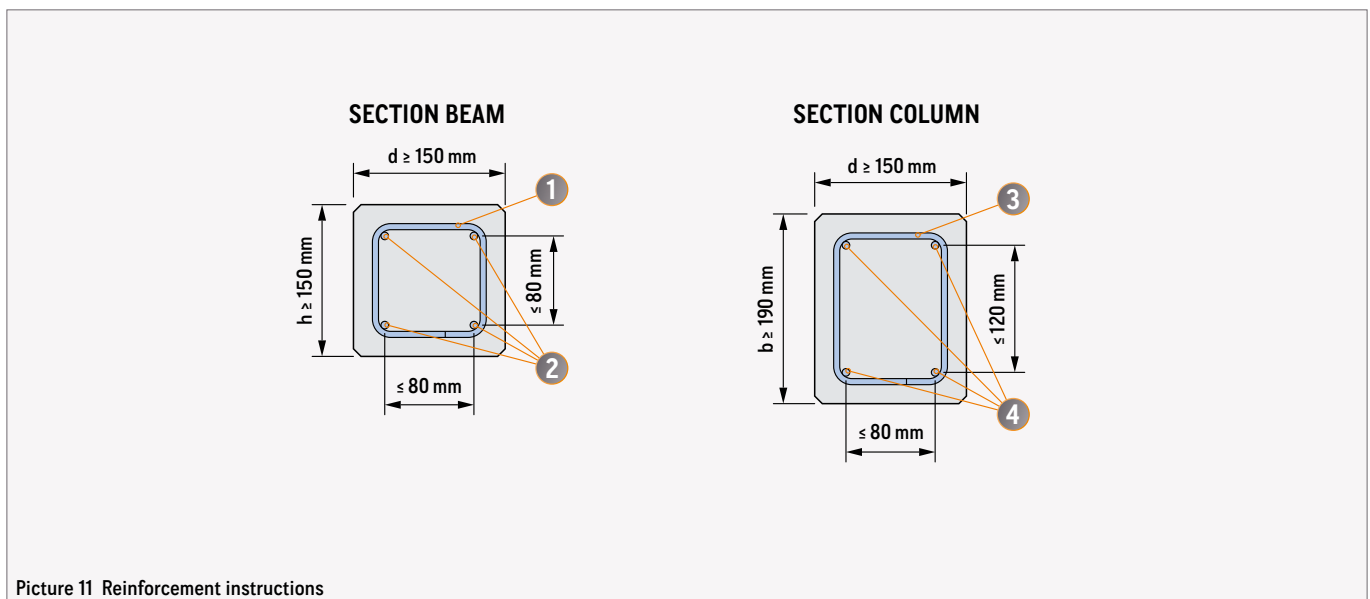

Picture 11 Reinforcement instructions

PHILIPP Cast-in lifting box

CAST-IN LIFTING BOX IN BEAM-LIKE ELEMENTS

In case of an installation in beam-like elements, the minimal dimensions of the concrete element as well as edge and centre distances given in have to be considered. For the information about required reinforcement please also refer to table 5. Data of required reinforcement are given in table 6 as well.

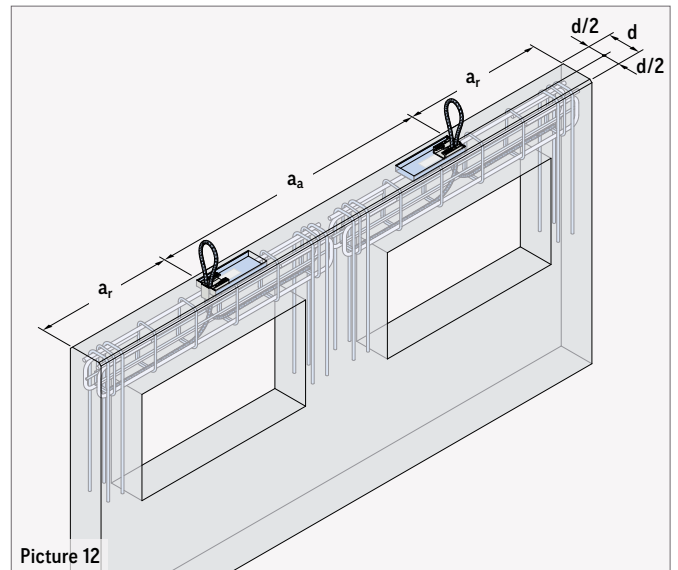

Picture 12

TABLE 5: AXIAL AND DIAGONAL TENSION IN BEAM-LIKE ELEMENTS

Load class	Min. element thicknesses min. centre and edge distances						Anchorage of the wire rope			$\beta_{\max} 30^\circ / \gamma_{\max} 7.5^\circ$ ① perm. F_Z		
	d (mm)	a_a (mm)	a_r (mm)	b (mm)	b_S ⑥ (mm)	h (mm)	e (mm)	r_{\min} (mm)	r_{\max} (mm)	$f_{cc} \geq 15 \text{ N/mm}^2$ (kN)	$f_{cc} \geq 17.5 \text{ N/mm}^2$ (kN)	$f_{cc} \geq 20 \text{ N/mm}^2$ (kN)
4.0	150	1200	600	200	≤ 800	200	160	72	110	19.0	20.5	21.9
		1350	675	275	≤ 800	320	280		220	32.5	35.1	35.1

① In combination with a tilting table is a sling angle of $\gamma_{\max} 15^\circ$ is possible!

⑥ For $b_S > 800 \text{ mm}$, the load transfer in the beam must be ensured by the user personally.

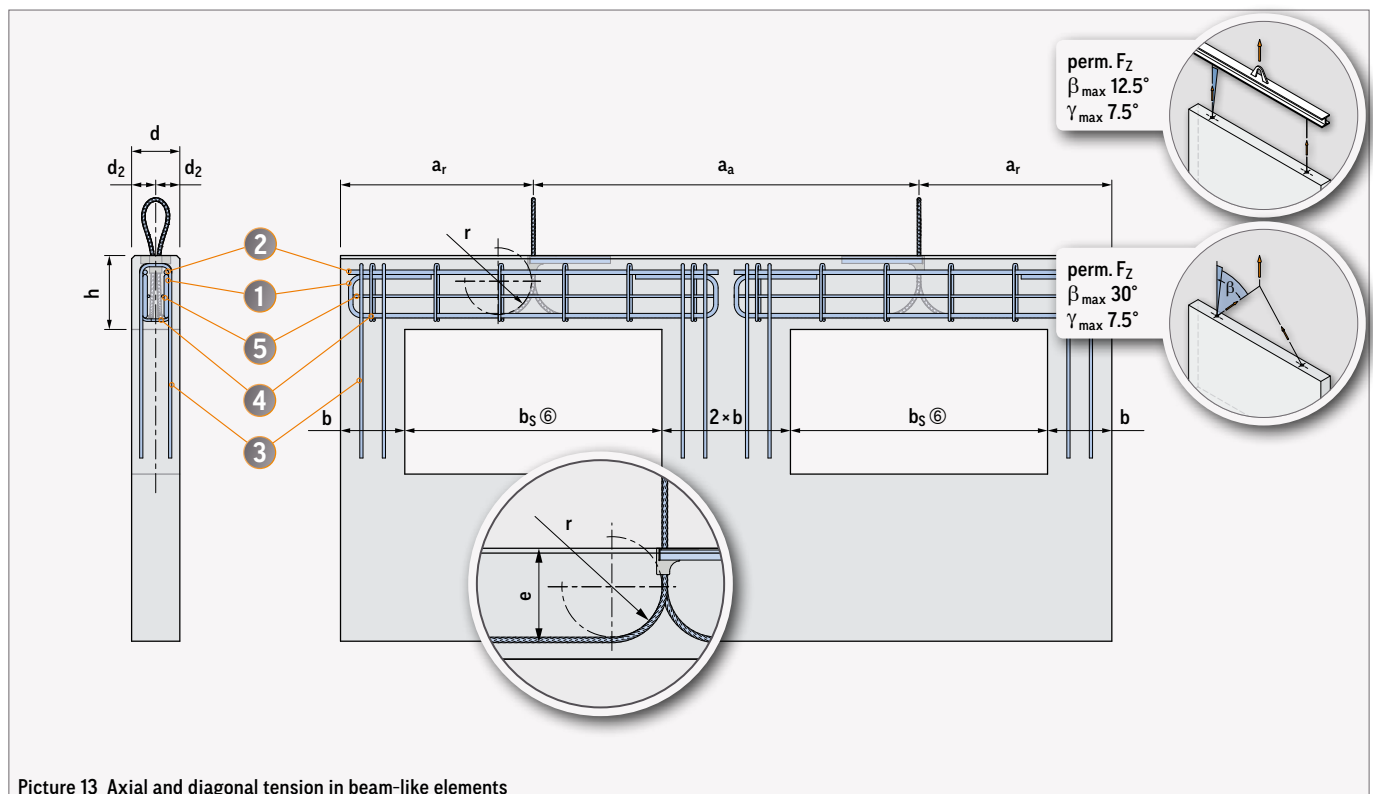

Picture 13 Axial and diagonal tension in beam-like elements

CAST-IN LIFTING BOX IN BEAM-LIKE ELEMENTS

TABLE 6: REINFORCEMENT

Load class	Beam height h (mm)	① Loop (B500A/B)			② Longitudinal reinforcement (B500A/B)		③ U-bar (B500A/B)			④ ⑦ Stirrup (B500A/B)		⑤ Longitudinal reinforcement (B500A/B)	
		$\varnothing d_{S1}$ (Quantity × mm)	L_{S1} (mm)	$\varnothing d_{br1}$ (mm)	$\varnothing d_{S2}$ (Quantity × mm)	L_{S2} (mm)	$\varnothing d_{S3}$ (Quantity × mm)	L_{S3} (mm)	$\varnothing d_{br3}$ (mm)	$\varnothing d_{S4}$ (mm)	$\varnothing d_{br4}$ (mm)	$\varnothing d_{S5}$ (mm)	L_{S5} (mm)
4.0	≥ 200	2 × Ø14	1150	56	2 × Ø12	1150	4 × Ø10	600	40	Ø8 / 100	40	Ø8	1150
	≥ 320	2 × Ø12	1300	48	2 × Ø10	1300	2 × Ø12	700	48	Ø8 / 200	48	Ø8	1300

⑦ The stirrups ④ can be replaced by a comparable mesh reinforcement.
 This requirement is fulfilled by e.g. using a mesh reinforcement:
 - at a beam height $h \geq 200$: type Q424 A (equal 4.24 cm²/m)
 - at a beam height $h \geq 320$: type Q257 A (equal 2.57 cm²/m)
 Existing reinforcement may be taken into account.

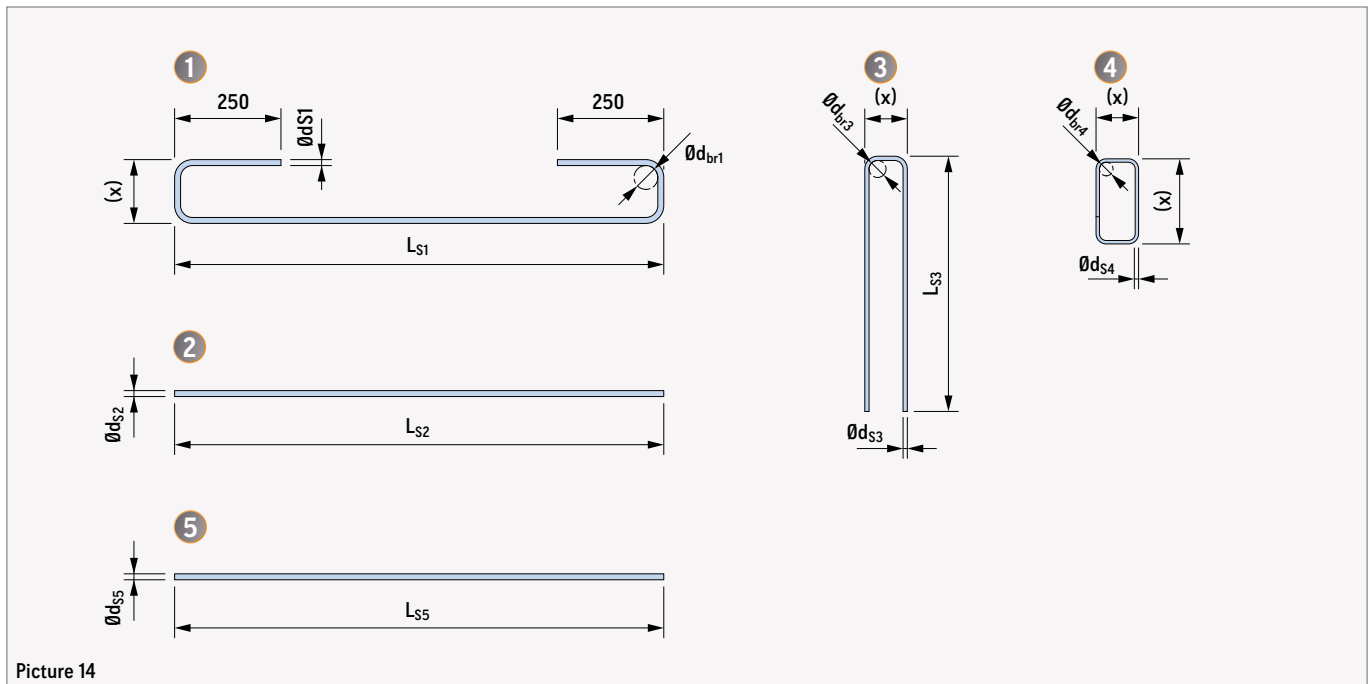

Picture 14

The measures marked with (x) depend on the respective element dimensions.

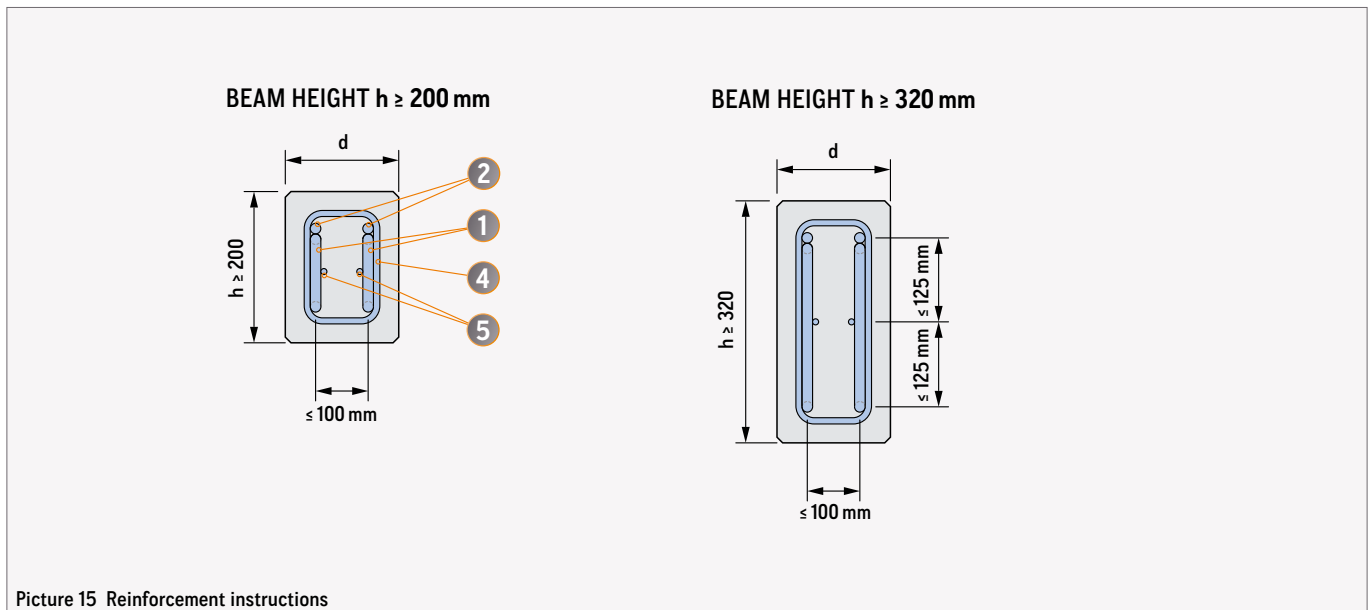

Picture 15 Reinforcement instructions

PHILIPP Cast-in lifting box

GENERAL PRODUCT INFORMATION

MARKING

The Cast-in lifting box is marked with a label both outside and inside (visible even during application) the box. The inner label must be visible even after being cast in concrete.

Following data are given on the tag:

Visible before casting (installation)

- » Manufacturer (PHILIPP)
- » Reference number
- » Type (AS 4.0)
- » CE mark ®
- » Installation direction (arrow)
- » QR code (Installation and Application Instruction)

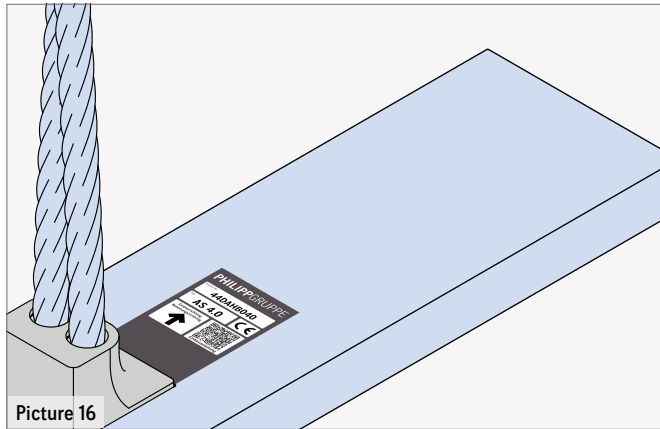

EC-DECLARATION OF CONFORMITY

The EC Declaration of Conformity (DoC) ® of the Cast-in lifting box can be downloaded from our website www.philipp-group.de or is available on request.



Visible after installation (transport)

- » Manufacturer (PHILIPP)
- » Reference number
- » Type (AS 4.0)
- » CE mark ®
- » QR code (Installation and Application Instruction)
- » Permissible load directions

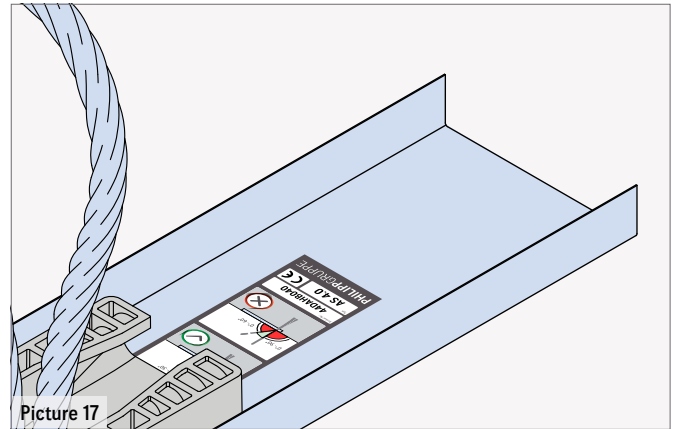

INSTALLATION

The Cast-in lifting box can be installed by nailing or hot bonding. Here, the labelling of the lifting direction (later loading direction of the transport anchors) has to be noticed (picture 20). This must point towards the centre of the panel (centre of gravity, picture 21). If the box is fixed to the formwork using nails, this shall be done at the points recommended in picture 18 in order to avoid

damaging the wire rope of the box. The wire rope ends of the box must be fixed to the opposite surface reinforcement in order to prevent a change in position during the concreting process. If necessary, more reinforcement can be added to secure the position (picture 22).

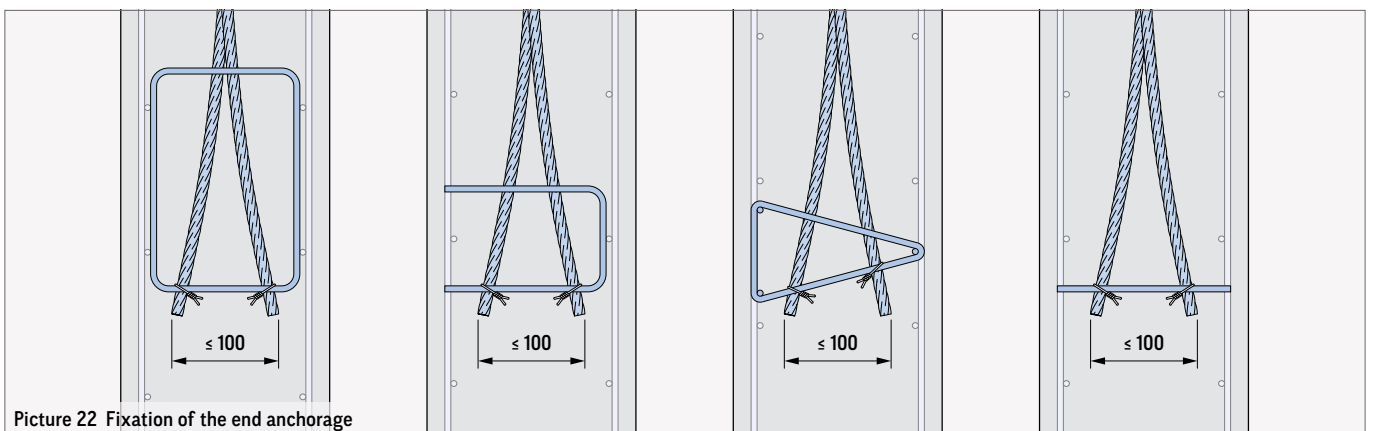
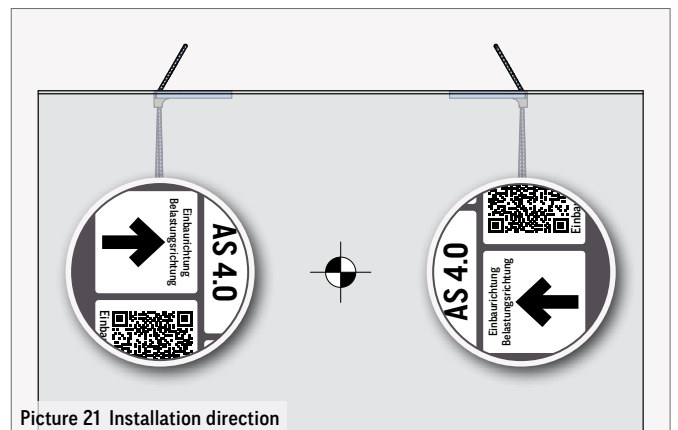
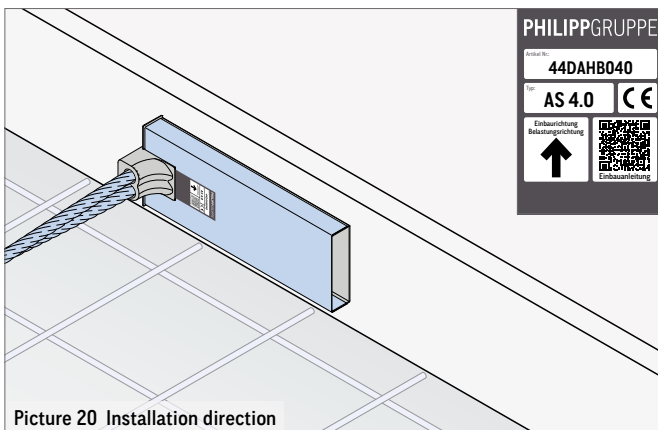
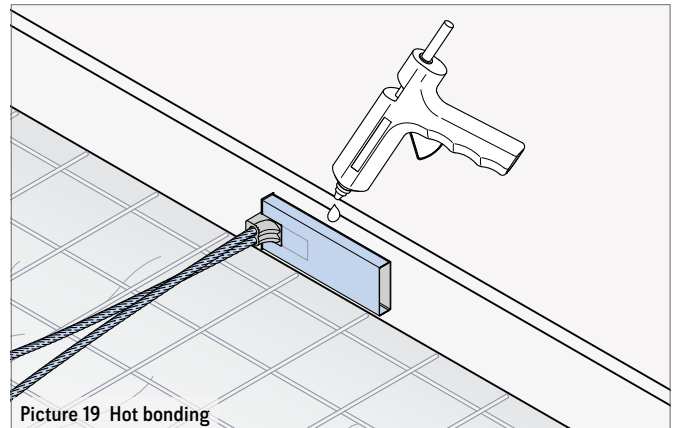
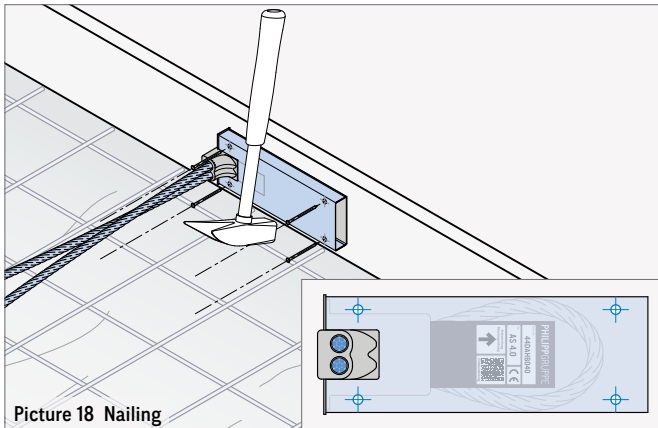

PHILIPP Cast-in lifting box

PREPARATION FOR APPLICATION / SAFETY INSTRUCTIONS

PREPARATION FOR APPLICATION

The cover of the box set in concrete must be loosened at one end. Then, it can then be easily removed.

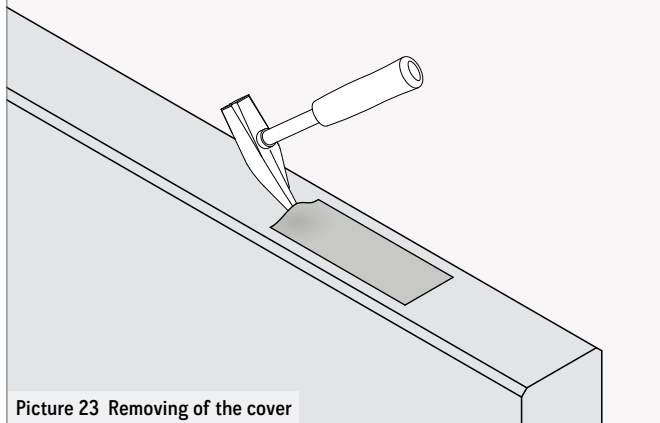

After that, the loop in the box can be folded out to lift the element now.

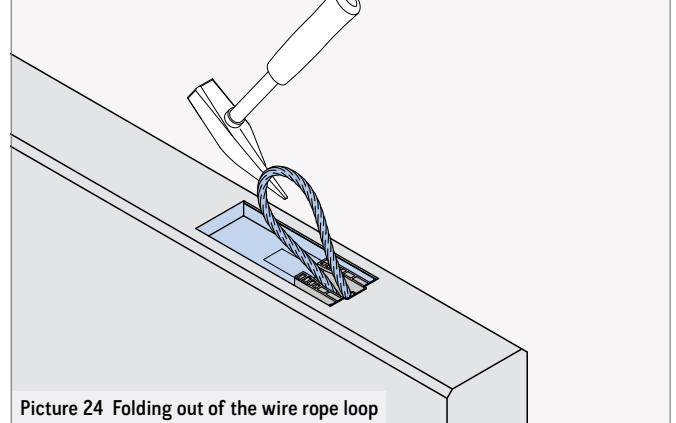

SAFETY NOTICES

By using too small, too large or sharp-edged hooks the lifetime of the transport anchor will be reduced. The transition radii of used hooks must be at least 1.75 times of the wire rope diameter of the Cast-in lifting box (picture 25). Using a shackle the pin must be at least 3.5 times of the wire rope diameter of the Cast-in lifting box (picture 26).

THE FOLLOWING POINTS NEED TO BE TAKEN INTO CONSIDERATION WHILE USING THE CAST-IN LIFTING BOX:

- » The use of damaged Cast-in lifting boxes with broken strands, contusions, kinks or corrosion pits is not allowed.
- » Contact of Cast-in lifting boxes because of wrong load directions must be also avoided.
- » Misuse because of incorrect load directions must be avoided.
- » Lever arms caused by rotating, tilting and swinging which result in local blow-out failures in the concrete or broken wire ropes are inadmissible!

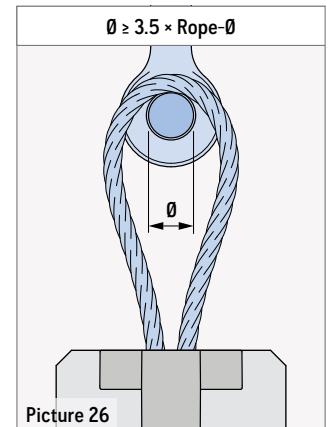
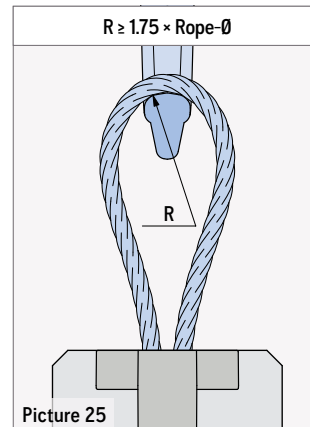

WELDING

Welding or other strong heat influences on the lifting boxes are not allowed.

NOTES

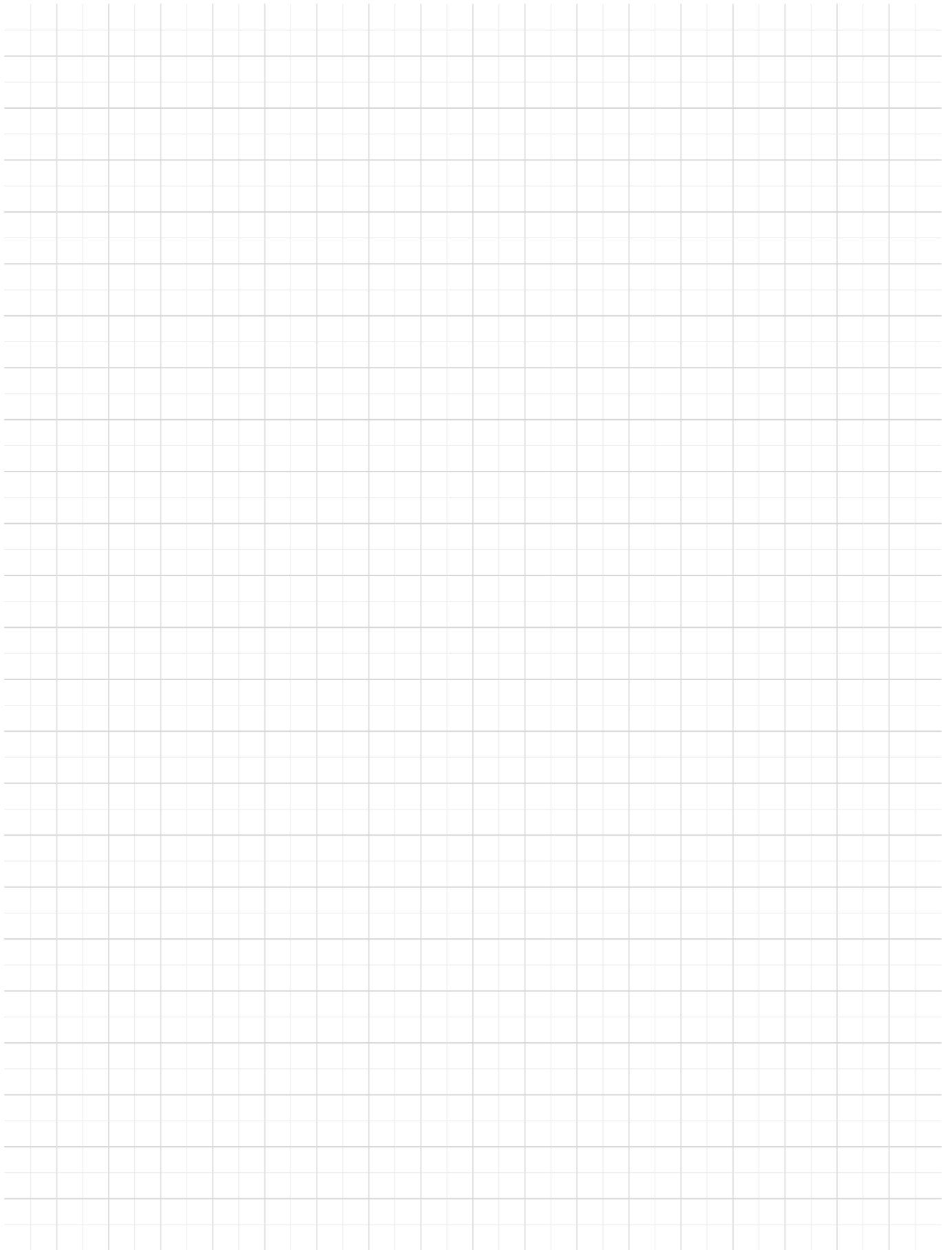



**PHILIPP GmbH
Headquarters**

Lilienthalstraße 7-9
63741 Aschaffenburg

+49 6021 40 27-0

info@philipp-gruppe.de

**PHILIPP GmbH
Production and logistics**

Hauptstraße 204
63814 Mainaschaff

+49 6021 40 27-0

info@philipp-gruppe.de

**PHILIPP GmbH
Office Coswig**

Roßlauer Straße 70
06869 Coswig/Anhalt

+49 34903 6 94-0

info@philipp-gruppe.de

**PHILIPP GmbH
Office Neuss**

Sperberweg 37
41468 Neuss

+49 2131 3 59 18-0

info@philipp-gruppe.de



PHILIPP Vertriebs GmbH

Pfaffing 36
5760 Saalfelden / Salzburg

+43 6582 7 04 01

info@philipp-gruppe.at



Visit us!

www.philipp-group.de